



PSAC 04244SEP
v.1.0

PSAC 24VAC/4A/4x1A/SEP

AC power supply for CCTV

EN*

Edition: 3 from 16.09.2013

Supersedes the edition: 2 from 05.07.2012



Features of the power supply unit:

- power output 4x 1A/24V AC or 27V AC
- power voltage 230V AC
- 4 independent, galvanically separated outputs
- 4 outputs protected independently by 1A fuses
- jumper selectable fuse type: glass fuse or polymer fuse
- LED indication
- AW technical output indicating AC power loss - relay
- protections:
 - SCP short-circuit protection
 - overvoltage protection
 - OLP overload protection
 - against tampering
 - OHP overheat protection of transformer
- warranty – 5 year from the production date

CONTENTS:

1. Technical description.
 - 1.1. General description
 - 1.2. Block diagram
 - 1.3. Description of PSU components and connectors
 - 1.4. Specifications
2. Installation.
 - 2.1. Requirements
 - 2.2 Installation procedure
3. Operating status indication.
 - 3.1. LED indication
 - 3.2. Technical output
4. Operation and use.
 - 4.1. Overload and short-circuit
 - 4.2. Maintenance

1. Technical description.

1.1. General description.

The AC/AC **PSAC 04244** PSU intended for supplying CCTV system devices requiring voltage of **24V AC or 27V AC** and total capacity of **4A@24V AC**. It features 4 outputs protected independently, galvanically separated with glass or polymer fuses. Output voltage range is step-adjustable by appropriate jumpers, independently for each AUX output. The PSU is housed in a metallic enclosure that features a microswitch indicating unwanted opening of the front door (faceplate).

1.2. Block diagram (fig.1).

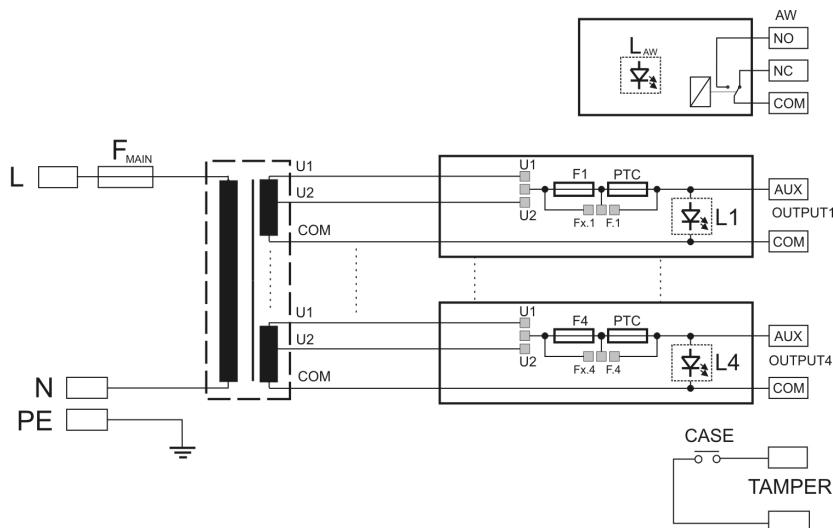

Fig.1. Block diagram of the PSU

1.3. . Description of PSU components and connectors.

Table 1. Terminals and elements of LB4-SEP.

Element No. [Fig. 2]	Description
[1]	L1÷L4 - LED (green) indicating the status of L1=OUT1 output, etc.
[2]	F1÷F4 fuses in output circuits, F1=OUT1 etc.
[3]	COM-U1-U2 Input of the AC supply (transformer separation required)
[4]	OUT1, OUT2, OUT3, OUT4 independently protected outputs
[5]	L _{AW} LED (red) indicating failure at one of the outputs (fuse activation)
[6]	AW output indicating failure at one of the outputs, relay type. Attention! In Fig.2. the set of contacts indicates potential-free status which corresponds to power supply failure.
[7]	Jumper-based fuse selection (glass fuse or polymer fuse) Fx Fx.x <input type="checkbox"/> <input type="checkbox"/> Fx jumper on, glass fuse selected Fx Fx.x <input type="checkbox"/> <input type="checkbox"/> Fx.x jumper on, polymer fuse selected
[8]	Jumper of the output voltage change (independently for each output): U2 U1 <input type="checkbox"/> <input type="checkbox"/> U1 jumper on, voltage at the output OUTx= 24V AC U2 U1 <input type="checkbox"/> <input type="checkbox"/> U2 jumper on, voltage at the output OUTx= 27V AC

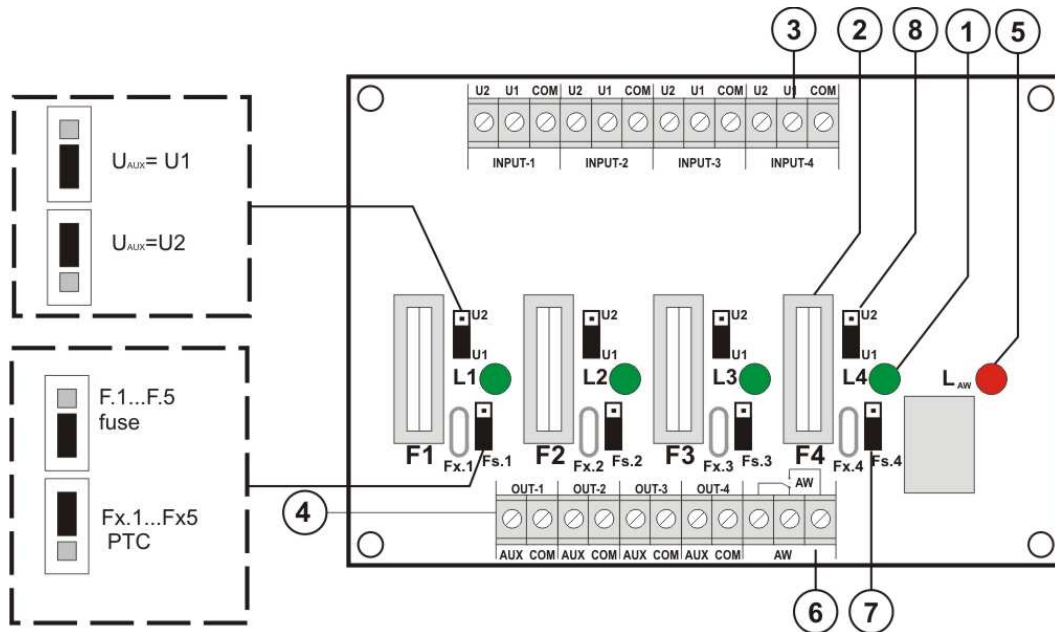



Fig.2. View of the LB4-SEP fuse block..

Table 2. Terminals and elements of PSAC 04244SEP.

Element No. [Fig. 4]	Description
[1]	Isolation transformer
[2]	Fuse block LB4-SEP (tab. 1)
[3]	TAMPER, tampering protection contact (NC)
[4]	F _{MAIN} fuse in supply circuit (230V AC)
[5]	L-N connection of 230 V AC power supply,  PE protection connection

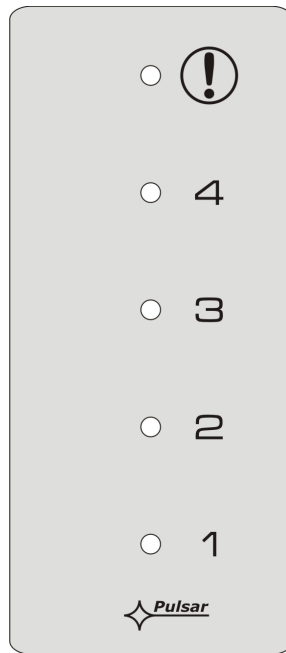

Fig.3. View of the PSU's panel.

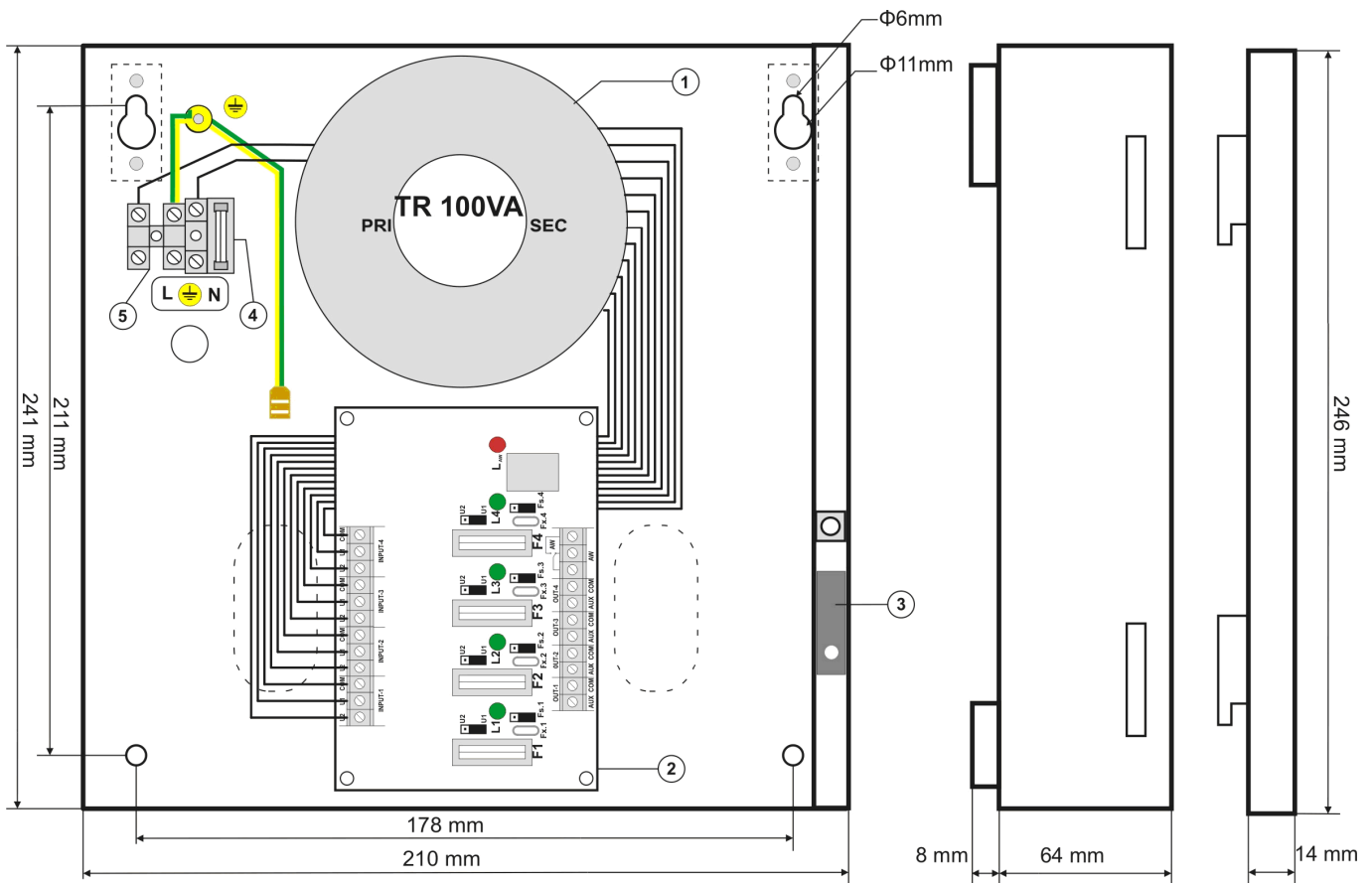

Fig.4. The view of the power supply.

1.4. Specifications:

- electrical specifications (tab.3)
- mechanical specifications (tab.4)
- operation safety (tab.5)
- operating specifications (tab.6)

Electrical specifications (table 3).

Mains supply	230V AC (-15%/+10%)
Current consumption	0,5 A max.
Power frequency	50 Hz
PSU power	100VA max.
Output voltage	U1 : 23,0÷28,0V AC (100% load ÷ 0% load) U2 : 25,5÷31,5V AC (100% load ÷ 0% load)
Voltage setting range	U1/U2 (jumper selectable)
Output current	4x 1A Σ 4,0A@24V AC max or 4x0,9A Σ 3,7A@27V AC max
Short-circuit protection SCP	4x F 1,0A glass or PTC 1A - glass fuse damage requires fuse-element replacement
Overload protection OLP	AC 24V circuit : 4x F 1,0A or PTC 1A (jumper selectable) AC 230V circuit : 1x T 1,0A
Overvoltage protection	varistors
Overheat protection OHP	yes- transformer
Tampering protection: - TAMPER output indicating enclosure opening	- microswitch, NC connectors (closed casing), 0.5A@50V DC (max.)
Technical outputs: - AW output indicating failure of one of the AUX outputs (fuse activation)	relay type, 1A@ 30V DC/50V AC max. Caution!! In Fig.2. the set of contacts indicates potential-free status which corresponds to power supply failure.
LED indication: LED L1÷L4 (green)	- status of OUT1 ÷ OUT4 normal status = illuminated, failure status = not illuminated
LED L _{AW} (red)	- failure indication of min. one output normal status = not illuminated, failure status = illuminated
F _{MAIN} fuse F1÷F4 fuses	T 1A/ 250V F 1A/ 250V or PTC 1A

Mechanical specifications (table 4).

Enclosure dimensions	210 x 241 x 64 (215 x 246 x 56+8) (WxHxD)
Fixing	178 x 211 4x Φ 6
Net/gross weight	2,70/2,90 kg
Enclosure	Steel plate DC01 0,7mm thick, colour RAL9003
Closing	Cheese head screw (at the front)
Connectors	Supply: Φ 0.63÷2.50 (AWG 22-10) Outputs: Φ 0.41÷1.63 (AWG 26-14) TAMPER output: cables of 25cm
Notes	The casing is equipped with distance from the mounting basis in order to guide the wiring system, convection cooling.

Operation safety (table5).

PN-EN 60950-1:2007 protection class	I (first)
PN-EN 60529: 2002 (U) protection grade	IP20
Electrical strength of insulation: - between the input (network) circuit and output circuits of the power supply (I/P-O/P) - between the input circuit and the PE protective circuit (I/P-FG) - between the output circuit and the PE protective circuit (O/P-FG)	3000V AC min. 1500V AC min. 500V AC min.
Insulation resistance: - between the input circuit and the output or protective circuit	100 M Ω , 500 V DC

Operating specifications (table 6).

Operating temperature	-10°C...+40°C
Storage temperature	-20°C...+60°C
Relative humidity	20%...90% without condensation
Vibrations during operation	unacceptable
Impulse waves during operation	unacceptable
Direct exposure to sunlight	unacceptable
Vibrations and Impulse waves during transport	according PN-83/T-42106

2. Installation.**2.1 Requirements.**

The AC/AC power supply is to be mounted by a qualified installer, holding relevant permits and licenses (applicable and required for a given country) for 230V/AC interference and low-voltage installations. The unit should be mounted in confined spaces, in accordance with the 2nd environmental class, with normal relative humidity (RH=90% maximum, without condensation) and temperature from -10°C to +40°C. The PSU shall work in a vertical position that guarantees free convectonal air flow through the ventilating holes of the enclosure

Before installation is started, the balance of the power-supply load shall be performed. During normal operation total current drawn by the receivers cannot exceed **I=4.0A@24V AC**. As the PSU is designed for a continuous operation and is not equipped with a power-switch, therefore an appropriate overload protection in the power supply circuit shall be guaranteed. Moreover, the user shall be informed about the method of unplugging (usually through assigning an appropriate fuse in the fuse-box). The electrical system shall follow valid standards and regulations.

2.2 Installation procedure.

- 1. Before installation, make sure that the voltage in the 230V power-supply circuit is cut off.**
2. Mount the power supply in the selected location and connect the wires.
3. Connect the power cables (~230V AC) with L-N power supply terminals. Connect the ground wire to the terminal marked by the earth symbol – “⊕”. Use a three-core cable (with a yellow and green PE protection wire) to make the connection. Lead the cables to the appropriate terminals of the connection board through the bushing.



The circuit of the shock protection shall be performed with a particular care, i.e. the yellow and green wire coat of the power cable shall stick to one side of the terminal marked with the '⊕' earth symbol in the PSU enclosure. Operation of the power supply without a properly made and fully operational shock protection circuit is UNACCEPTABLE! It can result in device damage or an electric shock.

4. . Connect the cables of receivers to the **OUT1÷OUT4** terminals on LB4-SEP fuse block.
5. If necessary, connect devices' wires (alarm panel, controller, indicator, etc.) to the PSU's technical outputs:
 - **AW** output indicating fuse activation (output of the LB4-SEP fuse block).
 - **TAMPER** output indicating unwanted opening of the PSU enclosure
6. In case of installation, where significant voltage drops occur in the resistance of the cables leading to the receivers, there is a possibility of voltage value correction by the U1/U2 jumpers, independently for each output.
7. Connect 230V AC supply.
8. Check LED indication for PSU operating status: LED L1÷L4 (green) should be constantly illuminated.
9. Once the installation and operation control have been completed, the enclosure can be locked.

3. Operating status indication.

The PSU is equipped with LED indication the status of operation. The presence of power at the outputs of the PSU is indicated by the illumination of green LEDs on the PCB of the LB4-SEP fuse block. A failure is indicated by the red LED [!] **AW**. The PSU status can be remotely controlled by the AW technical output.

3.1 LED indication.

LED L1...L4 (green) indicate power at the OUT1÷OUT4 outputs.

In case of a power loss at the output (blown fuse/PTC activation), an appropriate diode goes out (L1 for OUT1, L2 for OUT2, etc.).

- **LED [!] AW** (red) indicates a failure of at least one output (number of the output is indicated by the green LED L1÷L4).

3.2 Technical outputs.

The PSU is equipped with indication output, enabling to provide information about a failure or tampering.

AW – relay type output indication the activity of one of the output fuses.

Caution! In Fig.2. the set of contacts indicates potential-free status which corresponds to power supply failure.

TAMPER - output indicating opening of the PSU's enclosure, output of the potential-free contact indicating the door status, unit closed: NC, unit open: NO.

4. Operation and use.

4.1 Overload or short circuit at the PSU output.

The OUT1÷OUT4 outputs are protected against a short circuit with glass or polymer fuses. In case of fuse damage, the replacement of the same parameters is required.

If the polymer fuse-assisted protection has been chosen, there will be an automatic disconnection of the output voltage indicated by the green diode going out. Then, cut off the load from the PSU output for approx. 1 minute.

If the PSU is loaded with current exceeding $\Sigma 4,0A@24 V AC$ (110%for ÷ 150% of S power), there occurs the F fuse damage in the 230 V AC circuit and/or F1÷F4 fuses. In case of a failure, replace the fuse of the same parameters.

4.2 Maintenance.

All maintenance procedure may be performed following following the disconnection of the PSU from the power network. The PSU does not require performing any special maintenance measures. However, in case of a significant dust level, clean the interior with compressed air. In case of a fuse replacement, use one of the same parameters.

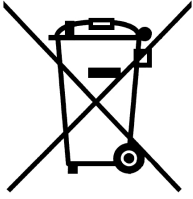
**WEEE MARK**

According to the EU WEE Directive – It is required not to dispose of electric or electronic waste as unsorted municipal waste and to collect such WEEE separately.

The power supply unit is adapted for a sealed lead-acid battery (SLA). After the operation period it must not be disposed of but recycled according to the applicable law.

GENERAL WARRANTY CONDITIONS

1. Pulsar K. Bogusz Sp.j. (the manufacturer) grants a five-year warranty for the equipment, counted from the device's production date.
2. The warranty includes free-of-charge repair or replacement with an appropriate equivalent (the selection is at the manufacturer's discretion) if the malfunction is due to the manufacturer, includes manufacturing or material defects, unless such defects have been reported within the warranty period (item 1).
3. The equipment subject to warranty is to be brought to the place where it was purchased, or directly to the main office of the manufacturer.
4. The warranty applies to complete equipment, accompanied by a properly filled warranty claim with a description of the defect.
5. Should the claim be accepted, the manufacturer is obliged to provide warranty repairs, at the earliest convenience, however not later than within 14 days from the delivery to the service centre of the manufacturer.
6. The repair period mentioned in item 5 may be prolonged, if there are no technical possibilities to carry out the repairs, or if the equipment has been conditionally accepted, due to the breaking warranty terms by the claimant.
7. All the services rendered by force of the warranty are carried out at the service centre of the manufacturer, exclusively.
8. The warranty does not cover the defects of the equipment, resulting from:
 - reasons beyond the manufacturer's control,
 - mechanical damage,
 - improper storage and transport,
 - use that violates the operation manual or equipment's intended use
 - fortuitous events, including lightning discharges, power failures, fire, flood, high temperatures and chemical agents,
 - improper installation and configuration (in defiance with the manual),
9. The warranty is void in any of the following circumstances:
 - construction changes
 - repairs carried out by any unauthorized service center
 - damage or removal of warranty labels
 - modifications of the serial number
10. The liability of the manufacturer towards the buyer is limited to the value of the equipment, determined according to the wholesale prices suggested by the manufacturer on the day of purchase.
11. The manufacturer takes no responsibility for the defects that result from:
 - the damaging, malfunctioning or inability to operate the equipment
 - defects that result from using the equipment outside its stated specifications and operating parameters failing to abide by the recommendations and requirements contained in the manual, or the use of the equipment.

Pulsar K. Bogusz Sp.j.

Siedlec 150, 32-744 Łapczyca, Poland
Tel. (+48) 14-610-19-40, Fax. (+48) 14-610-19-50
e-mail: biuro@pulsar.pl, sales@pulsar.pl
[http:// www.pulsar.pl](http://www.pulsar.pl)