

Operating Instructions

Included Installation Instructions

Base Bracket

Model No. **WV-QJB502-W**
WV-QJB502-G

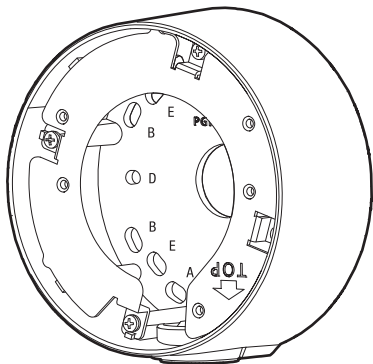

- Before attempting to connect or install this product, please read these instructions carefully and save this manual for future use.
- The external appearance and other parts shown in this manual may differ from the actual product within the scope that will not interfere with normal use due to improvement of the product.

Panasonic i-PRO Sensing Solutions Co., Ltd. assumes no responsibility for injuries or property damage resulting from failures arising out of improper installation or operation inconsistent with this documentation.

For U.S. and Canada:

Panasonic i-PRO Sensing Solutions Corporation of America
800 Gessner Rd, Suite 700 Houston, TX 77024
<https://www.security.us.panasonic.com/>

Panasonic Canada Inc.

5770 Ambler Drive, Mississauga, Ontario, L4W 2T3 Canada
1-877-495-0580
<https://www.panasonic.com/ca/>

For Europe and other countries:

Panasonic Corporation
<http://www.panasonic.com>

Panasonic i-PRO Sensing Solutions Co., Ltd.
Fukuoka, Japan

Authorised Representative in EU:

Panasonic Testing Centre
Panasonic Marketing Europe GmbH
Winsbergring 15, 22525 Hamburg, Germany

* PGQX2437ZA *



Ns1020-0
Printed in China

© Panasonic i-PRO Sensing Solutions Co., Ltd. 2020

Caution:

- Before attempting to connect or operate this product, please read these instructions carefully.

Notice:

- This product is not suitable for use in locations where children are likely to be present.
- Do not install this product in locations where ordinary persons can easily reach.
- For information about screws and other parts required for installation, refer to the corresponding section of this document.

Precautions

Do not use this bracket except with suitable cameras.

Failure to observe this may cause a drop resulting in injury or accidents.

Do not install this product on a place that is greatly influenced by wind.

Installation on a place where the wind speed is 60 m/s {approx. 134 mph} or more may cause a fall of the product resulting in injury or accidents.

Refer installation work to the dealer.

Installation work requires technique and experience. Failure to observe this may cause fire, electric shock, injury, or damage to the product. Be sure to consult the dealer.

Do not rub the edges of metal parts with your hand.

Failure to observe this may cause injury.

When using this product, also read the "Precautions" described in the operating instructions for the camera to be attached.

Preface

Mount the camera onto the ceiling or wall using this bracket.

Use this bracket when conduits are used for wiring, or when there is no space available for wiring in the ceiling or wall.

For the latest information about the supported cameras, refer to our support website (https://security.panasonic.com/training_support/support/info/ <Control No.:C0501>).

Specifications

Ambient operating temperature:	-50 °C to +60 °C {-58 °F to +140 °F}
Dimensions:	ø127 mm × 56.5 mm (H) {ø5 inches × 2-7/32 inches(H)}
Mass:	Approx. 460 g {1.02 lbs}
Finish:	Aluminum die cast i-PRO white <WV-QJB502-W> Light gray <WV-QJB502-G>

Precautions for installation

- In order to prevent injury, the product must be securely mounted to the wall or ceiling according to the Installation Guide of the camera.
- Make sure to remove this product if it will no longer be used.

Standard accessories

Operating Instructions (this manual) 1 pc.

The following parts are used during installation procedures.

Attachment plate	1 pc.	Fixing screw for attachment plate (M3×10 mm {13/32 inches})	5 pcs.
Fixing screw for camera (M4×10 mm {13/32inches})	4 pcs.	(of them, 1 for spare)	

Other items that are needed (not included)

- Fixing screw Recommended screw M4/4 or 2 pcs.
Minimum pull-out strength 196 N {44 lbf} (per 1 pc.)

Note:

- Select screws according to the material of the location that the camera will be mounted to. In this case, wood screws and nails should not be used.
- For information about the minimum pull-out strength, refer to our support website (https://security.panasonic.com/training_support/support/info/ <Control No.: C0120>)

Preparations

[1] Remove the enclosure from the camera.

Refer to the Installation Guide of the corresponding camera for how to remove the enclosure from the camera.

[2] Check the installation direction of the conduit and the image capturing direction of the camera

Check the connection direction of the conduit (direction of the cable access hole for conduit on this bracket) and the image capturing direction of the camera and then determine the fixing position of the attachment plate. The fixing position of the attachment plate can be changed with steps of 90°. The following is an example of the camera direction and the fixing position of the attachment plate when connecting the conduit from the upper side.

<When the image capturing direction is downward>

- Align the direction of the attachment plate so that the "↑TOP" mark of the attachment plate comes to the upper side.

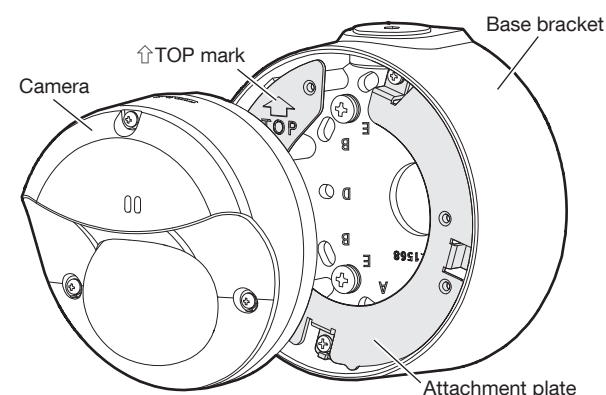

<When the image capturing direction is left side>

- Align the direction of the attachment plate so that the "↑TOP" mark of the attachment plate comes to the right side.

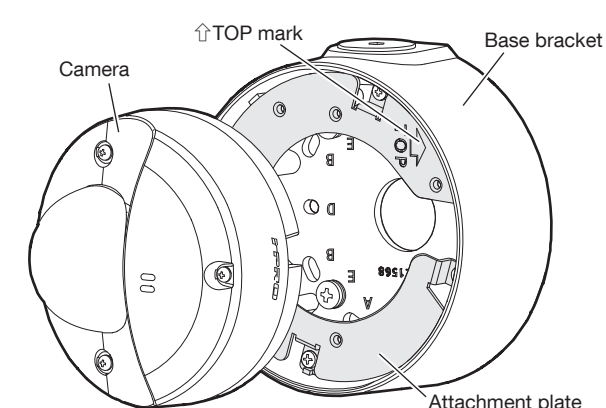

Note:

- The connection cables are omitted in the illustration.

Parts and functions

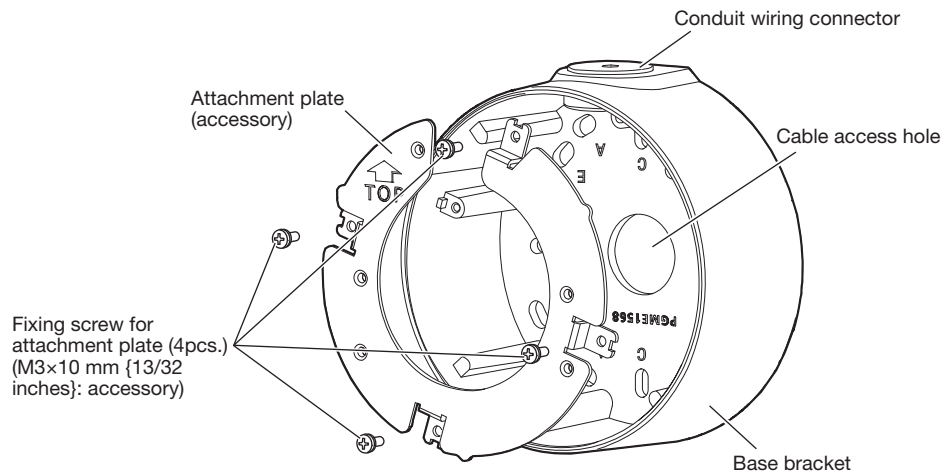

Installations

Step1 Make a hole on the installation surface.

- [1] Make screw holes or anchor holes in the ceiling or wall, and also cable access hole if necessary.
No cable access hole is needed when using conduit.

A 83.5 mm × 46 mm
{3-9/32 inches × 1-13/16 inches}/
82.5 mm × 47.6 mm
B {3-1/4 inches × 1-7/8 inches}

C 83.5 mm {3-9/32 inches}/
D 83.3 mm {3-9/32 inches}

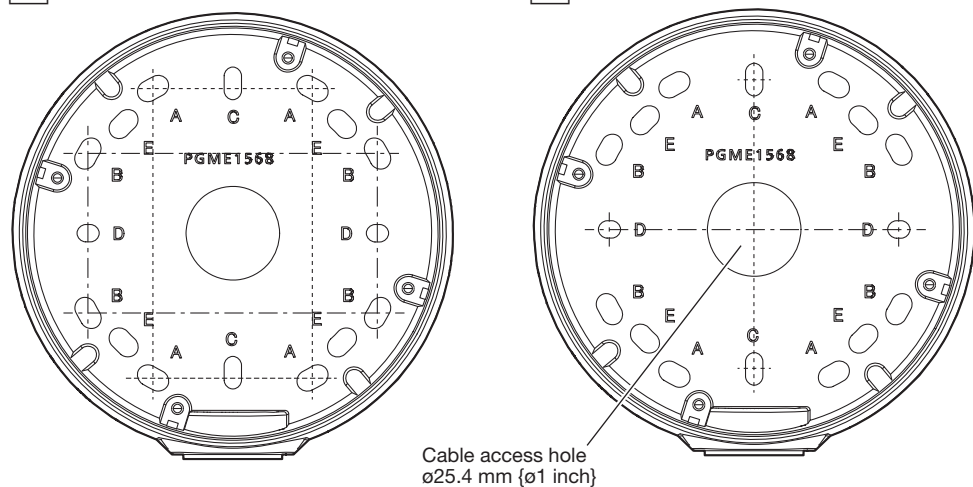

E 63 mm {2-15/32 inches}/
63 mm {2-15/32 inches}

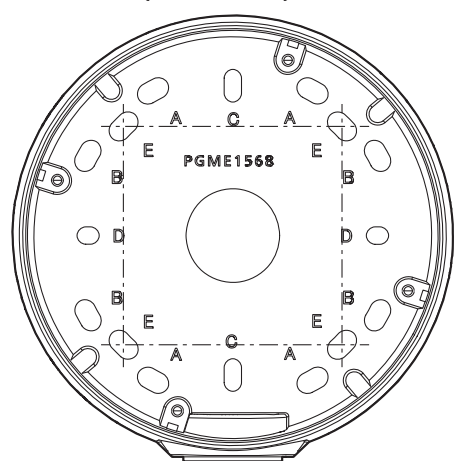

Note:

- When mounting to a single-gang junction box, fix it with screws (2 pcs.) (M4: locally procured).
- The direction of the attachment plate (installation direction of the camera) can be changed with steps of 90° even after the base bracket is fixed.

- [2] Remove the cap for the female thread for the conduit using a 5 mm {3/16 inches} hexagon wrench and attach the conduit.

The female thread for conduit is compliant with ANSI NPSM (parallel pipe threads) 3/4 or ISO 228-1 (parallel pipe threads) G3/4.

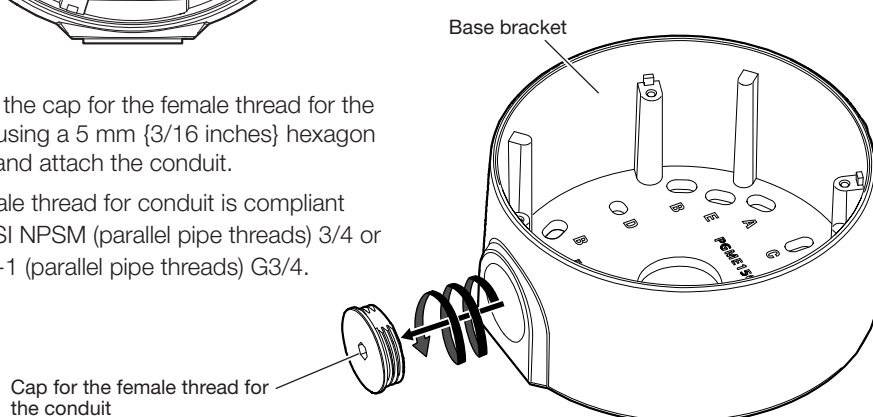

Step2 Fix the base bracket and install the attachment plate in the direction described in [2] of "Preparations".

- [1] Install the base bracket on the installation surface.
Fixing screws (4 pcs.) (M4: locally procured)
Minimum pull-out strength: 196 N {44 lbf} (per 1 pc.)
- [2] Install the attachment plate onto the base bracket.
The following is an example when this bracket is installed on the wall.
(Recommended tightening torque: 0.69 N·m {0.51 lbf-ft})

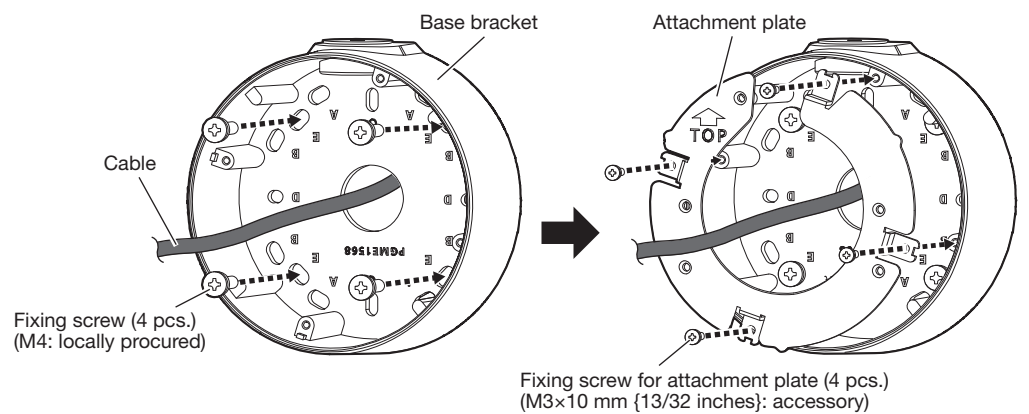

Note:

- When installing this bracket outdoors, be sure to apply waterproofing to the cable access hole and fixing screw holes.

Step3 Connect the cables to the camera.

Connect an Ethernet cable to the RJ45 network cable from the camera.
Refer to the Installation Guide of the camera for how to install the waterproof connector.

Step4 Fix the camera body to this bracket.

(Recommended tightening torque: 1.37 N·m {1.01 lbf-ft})

<When the camera is a model to be fixed with three fixing screws for camera>

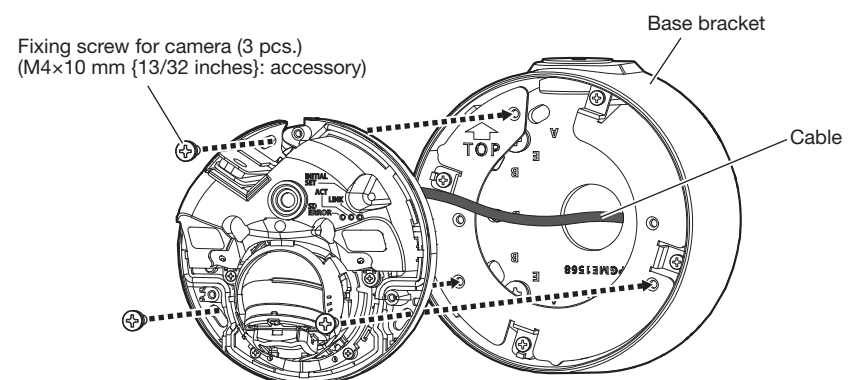

<When the camera is a model to be fixed with two fixing screws for camera>

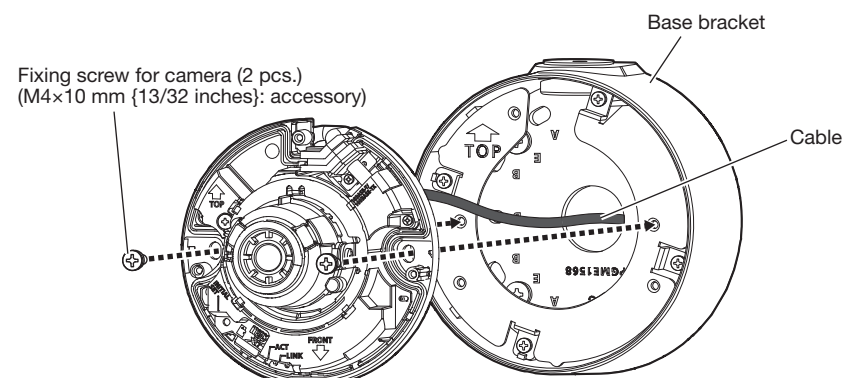

Note:

- When fixing the camera on this bracket, be careful not to pinch the cable with this bracket and damage the cable sheath.

Step5 Adjust the angle of view of the camera.

Turn on the power of the camera and adjust the angular field of view of the camera.
Refer to the Installation Guide of the corresponding camera for how to connect to a network and for how to adjust the angle of view of the camera.

Step6 Attach the enclosure.

After finishing the adjustment, attach the enclosure by following the instructions in the Installation Guide of the corresponding camera.

Refer to the Installation Guide of the corresponding camera for the recommended tightening torque to be applied when fixing the enclosure of the camera.